

X = 2.4 m (8') for minor roads
 X = 3 m (10') for collector roads

MINOR & COLLECTOR ROADS

(Commercial, multiple dwellings and single family residences)

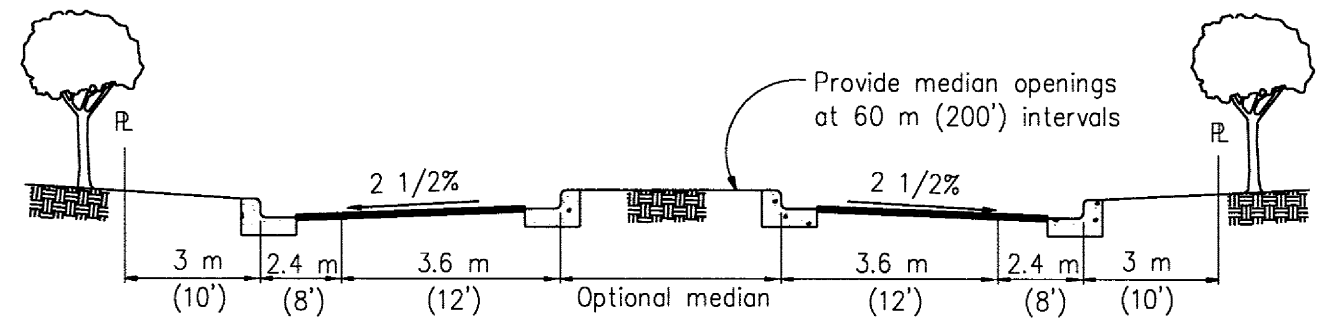

CUL-DE-SAC

(Multiple dwellings)
 Max length = 250 m (800')

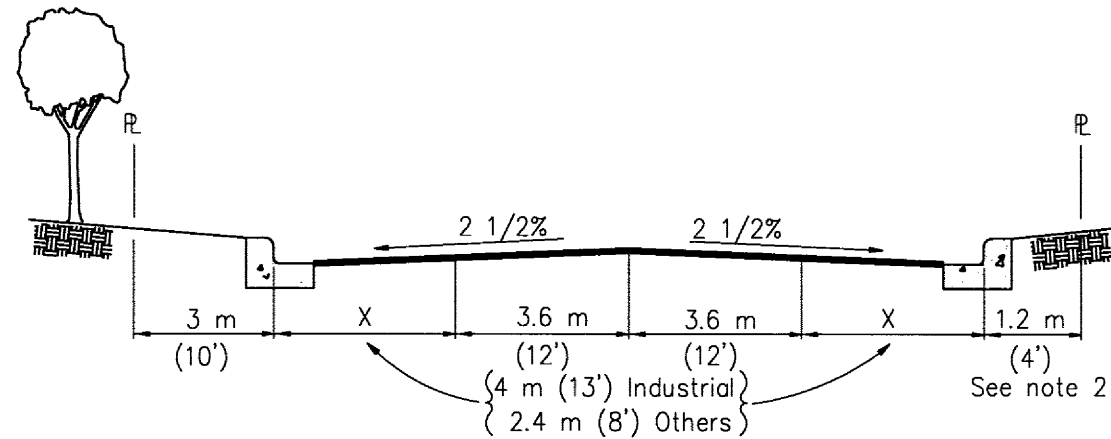

FRONTAGE ROAD

(Industrial, commercial and multiple dwellings)

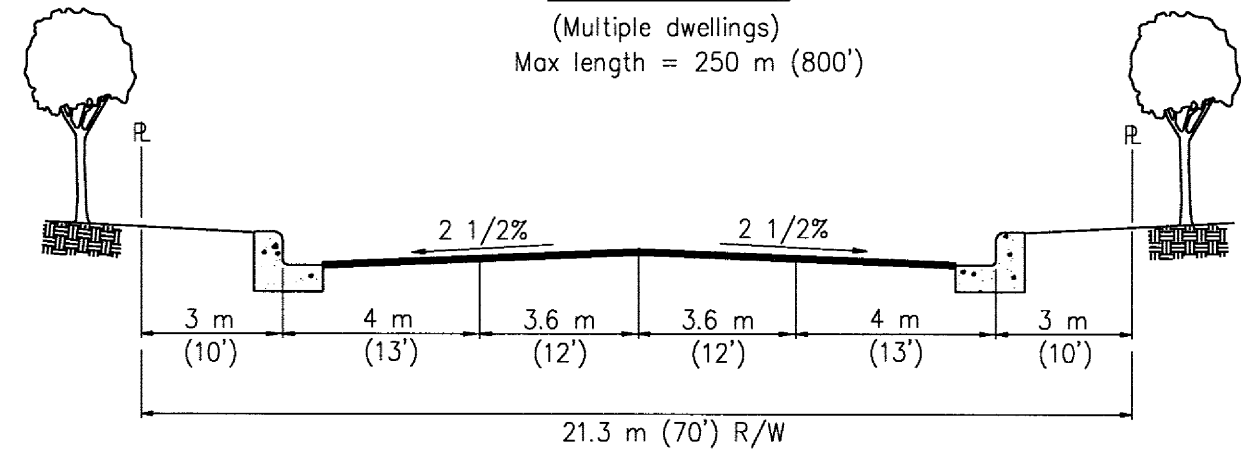

INDUSTRIAL ROAD

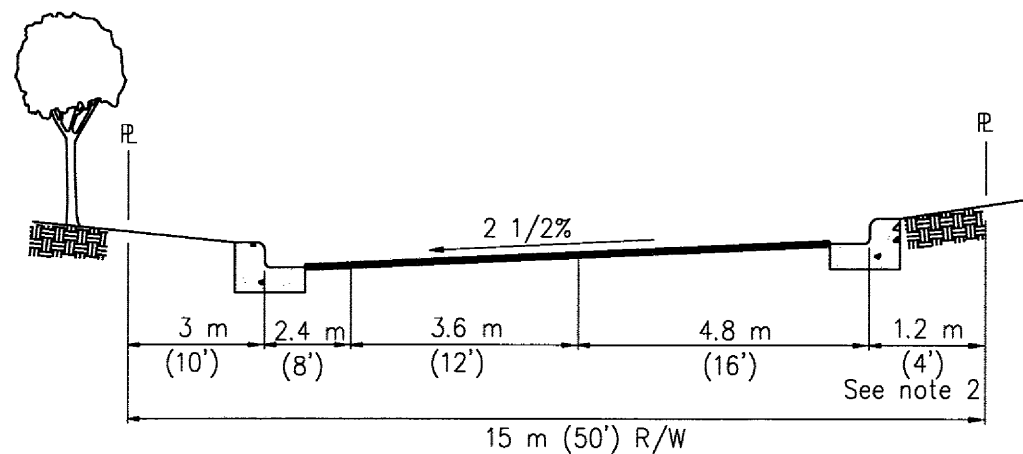

FRONTAGE ROAD

(Single family residences)

NOTES:

1. Refer to other standard details for border area layout, structural section, curb, gutter, sidewalk, street lights and utility locations.
2. Greater than 1.2 m (4') if bus stop facility or landscaping is required.
3. All collector roads are shown in County Road Book.
4. Structural section: Design approved by Road Commissioner based on developer-furnished TI and R-value, or structural section shall be supplied by Road Commissioner.
5. Border street trees and landscaping to be placed outside of R/W unless approved by the Road Commissioner.
6. See note A.5 in Notes section (page I).

METRIC (& ENGLISH) UNITS

		SANTA CLARA COUNTY ROADS AND AIRPORTS DEPARTMENT						STANDARD DETAILS COLLECTOR, INDUSTRIAL, & FRONTAGE ROADS TYPICAL SECTIONS		DRAWING NO. A SHEET NO. 2 1 of 1			
DESIGNED: VAP 09/26/97 DATE: STQ 09/26/97 DRAWN: VAP/TH 9/26/97 CHECKED:		DATE:		SUBMITTED:		APPROVAL:		PROJECT NO.		CONTRACT NO.		FILE NO.	