

GROUND CLAMP AND REQUIRED FITTINGS MUST BE ACCESSIBLE. CONDUIT MUST EXTEND TO GROUND ELECTRODE TO PROTECT GROUND WIRE FROM MECHANICAL INJURY.

TYPE A

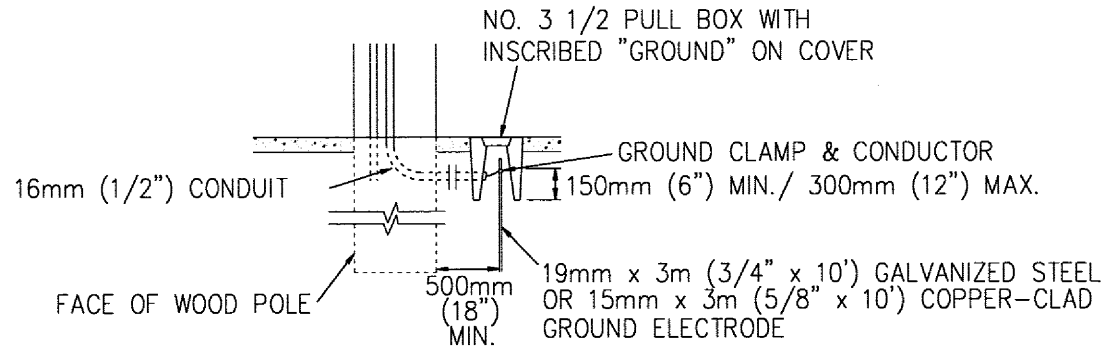



INSTALLATION SHOWN IS FOR SIDEWALK OR PAVED AREAS.
IN UNPAVED AREAS, TOP OF BOX SHALL BE RAISED 25mm (1") ABOVE GROUND.

TYPE B

B SERVICE GROUNDING

METRIC (& ENGLISH) UNITS

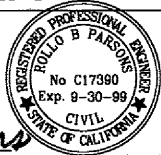
				SANTA CLARA COUNTY ROADS AND AIRPORTS DEPARTMENT				STANDARD DETAILS SERVICE POINT INSTALLATION		DRAWING NO. E 2A SHT NO. 2 of 2		
NO.	REVISIONS	BY	DATE	APP'D	DESIGNED TH 04/15/97 STQ 04/15/97 DRAWN TH 04/15/97 CHECKED	DATE DATE DATE	WORK ORDER LEVEL BOOK TRANSIT BOOK	SUBMITTED: 	APPROVAL: 	PROJECT NO.	CONTRACT NO.	FILE NO.