

A SIGNAL MOUNTING VERTICAL CLEARANCE

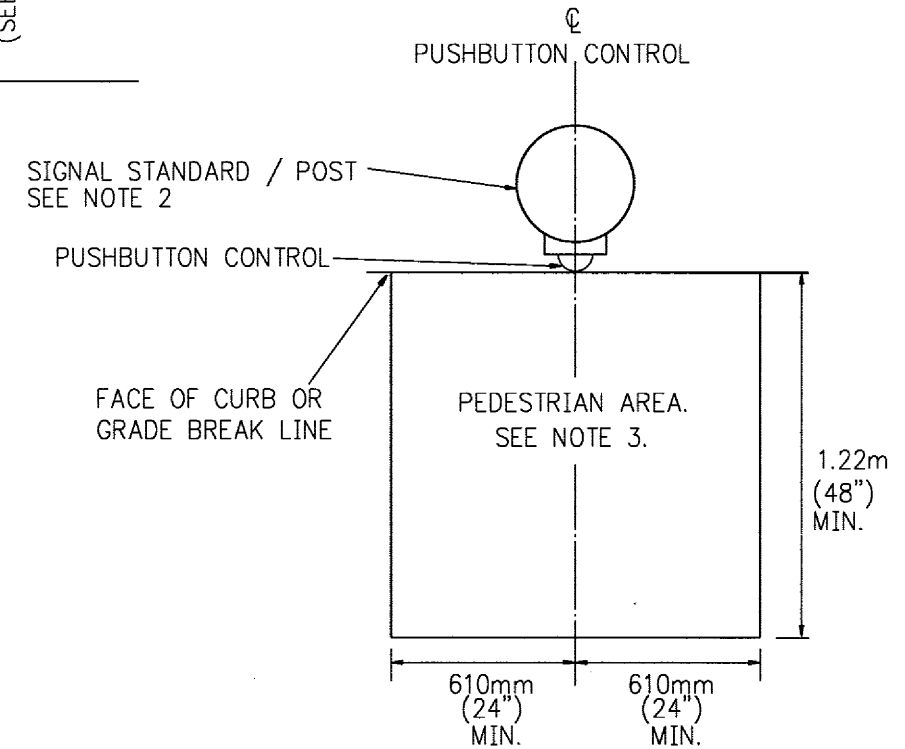

B TOP VIEW - PUSHBUTTON CONTROL MOUNTING HORIZONTAL CLEARANCE

NOTES :

- 1) THE SPECIFIED VERTICAL CLEARANCE SHALL BE MEASURED FROM THE CENTERLINE OF THE PUSHBUTTON CONTROL TO THE FINISHED SURFACE OF SIDEWALK / WALKWAY.
- 2) HORIZONTAL MINIMUM CLEARANCE BETWEEN STANDARD/POST AND TRAFFIC LANE FACE OF CURB SHALL BE MET.
- 3) PEDESTRIAN AREA SHALL BE LEVEL.

METRIC (& ENGLISH) UNITS

		SANTA CLARA COUNTY ROADS AND AIRPORTS DEPARTMENT	
NO.	REVISIONS	BY	DATE
APP'D	DATE	DATE	DATE
TH	04/15/97	DATE	DATE
DESIGNED	STQ	04/15/97	DATE
DRAWN	TH	04/15/97	DATE
CHECKED	DATE	DATE	DATE
WORK ORDER	LEVEL BOOK	TRANSIT BOOK	DATE
<i>William A. Balyas</i>		<i>Rullo B. Parsons</i>	
PROJECT NO.		CONTRACT NO.	
FILE NO.		FILE NO.	
STANDARD DETAILS SIGNAL MOUNTING CLEARANCE REQUIREMENTS			DRAWING NO. E 6A SHT NO. 1 of 1